

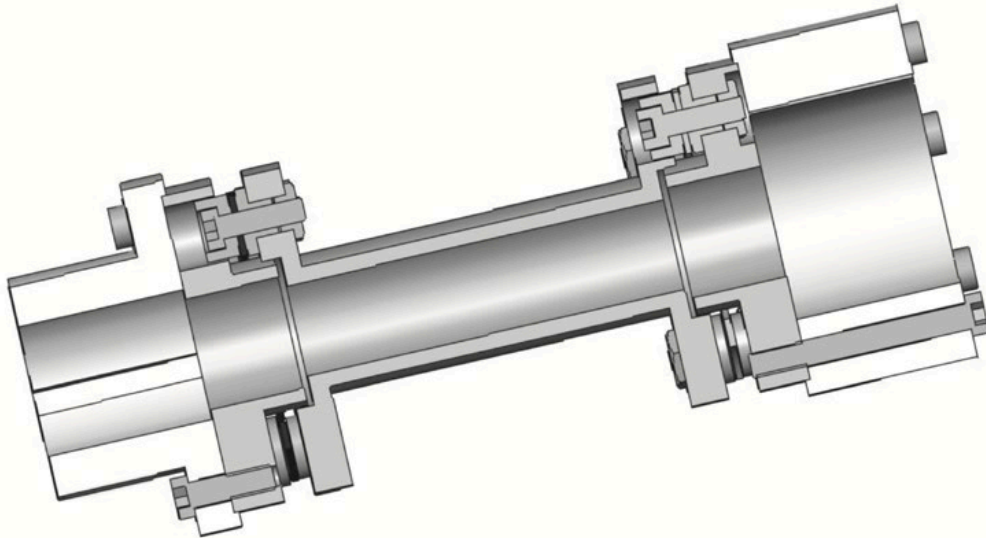

Disc-O-Flex Couplings - Type RSK



Disc-O-Flex couplings are fully metallic couplings, consisting of two hubs, one centre spacer member, two sets of stainless steel element blades bolted together with high tensile bolts. Replacement of element blades is easy, simple and is possible without disturbing drive or driven equipment.

Features

- High power-to-weight ratio.
- No wearing parts, no lubrication required.
- Easy installation with 'Drop Out' spacer.
- Accommodates angular, parallel and axial misalignments.
- Non stainless steel parts coated with a durable anticorrosive coating.
- High temperature application.
- Replaceable element blades with adapter.
- Visual inspection possible without disassembling equipment.
- Inherently balanced.
- High torsional rigidity with low axial stiffness.
- Special options including spacer lengths, modified hubs, special materials are available.
- Floating shaft/ cooling tower couplings are available.
- Backlash free.
- High speed capability.
- Dynamic balancing to customer specifications.
- Machined to high precision standards.
- Lightweight couplings.
- Specially suitable for Petrochemical & Fertilizer Industries.
- API 610 & API 671 compliance available on request.
- Coupling with anti-fly features.



Disc-O-Flex Couplings - Type RSK

Selection Procedure:

- 1 Select an appropriate SERVICE FACTOR from table given below.
- 2 Multiply the rated running power by the service factor. This gives DESIGN POWER at rated speed (rpm).
- 3 Now convert this to design power at 1000 rpm. This is used as a basis for coupling selection.
- 4 Refer to the rating column and read until the power greater than or equal to the design power at 1000 rpm is found. The size of the coupling is given in the corresponding first column.
- 5 Select either standard type I or type II hubs to suit shaft sizes.
- 6 Specify the distance between shaft ends (DBSE)

Service Factor:

Suggested service factors for electric motor, steam turbine, and gas turbine drivers are given below:

Duty		Service Factor
Constant Torque	Centrifugal Pump, Centrifugal Compressor Axial Compressor Centrifugal Blower	1.0*
Slight Torque Fluctuation	Screw Compressor Gear, Lobe and Vane Pumps Forced Draft Fan Medium Duty Mixer Lobe Blower	1.5
Substantial Torque Fluctuation	Reciprocating Pumps, Heavy Duty Mixers Induced Draft Fans	2.0

* Use a minimum service factor of 1.25 on electric motor drives through a gearbox.





Technical Data RSK

Coupling Size	Rating kW at 1000 rpm	Max. Continuous Torque Nm	Peak Overload Torque Nm	Max. rpm	Weight Transmission Unit		Weight Unbored Hubs - Kg	
					Std.	Extra DBSE kg/m	Hub I	Hub II
13	13	124	310	25500	1.5	3.1	1.0	1.9
33	33	315	790	20000	3.0	5.0	1.4	3.1
75	75	716	1790	16500	5.6	6.5	3.6	5.8
135	135	1289	3220	14400	9.3	10.5	5.9	8.7
230	230	2196	5490	12000	14.0	13.0	9.0	14.0
350	350	3342	8360	10500	18.7	22.0	16.4	-
500	500	4775	11940	9500	25.6	22.0	21.0	-
740	740	7066	17670	8000	34.2	27.5	30.0	-
930	930	8881	22200	7000	44.0	40.0	38.0	-
1400	1400	13369	33400	6000	54.0	40.0	52.1	-

Note that for the complete coupling, weights of two appropriate hubs plus a transmission unit are required.

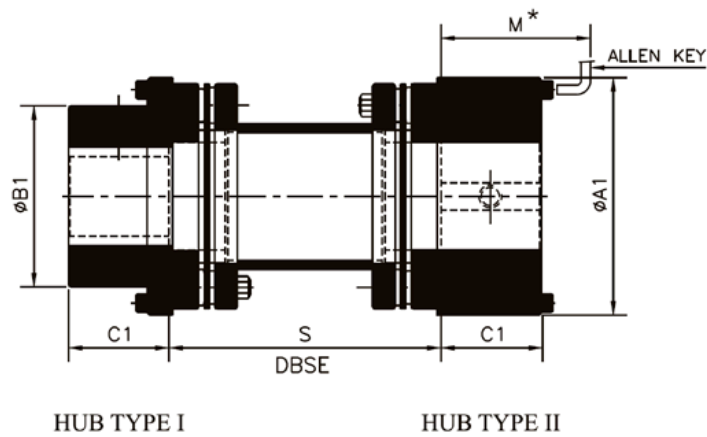

Technical Data

Coupling Size	Max. Bore		DBSE 'S min'	Std. DBSE 'S'	C1	ØA1	ØB1	M *
	Type I	Type II						
13	36	51	75	100 140 180	40	86	54	90
33	46	70	90		45	105	69	105
75	65	90	107	140 180 250	55	130	90	120
135	80	102	127		62	152	112	127
230	90	121	133		70	179	131	135
350	115	-	139	180 250	90	197	163	-
500	127	-	141		95	222	181	-
740	140	-	143		107	247	206	-
930	155	-	155		115	272	223	-
1400	172	-	175		130	297	248	-

Non Standard DBSE available on request.

Available for non-sparking application on request.

Please specify type of Hub.

* 'M' is only for hub type II.

For vertical installation contact.



Coupling Alignment

Correct installation and alignment of couplings is essential for reliable machinery performance.

Coupling Size	Max. Axial Misalignment *		Max. Parallel Misalignment **	
	+/- mm.	Equivalent Thrust kN	mm	Restoring Moment Nm
13	1.00	210	0.30	4.1
33	1.25	280	0.36	6.1
75	1.50	360	0.45	8.8
135	2.00	560	0.55	11.8
230	2.50	740	0.60	14.7
350	2.75	780	0.64	34.3
500	3.25	1080	0.65	40.7
740	3.75	1270	0.68	47.6
930	4.25	1470	0.72	53.9
1400	5.00	2700	0.83	61.3

- * Meets NEMA end float specification without modification.
- ** Values based on angular deflection of 0.5° per end and minimum DBSE. Greater misalignment accommodation is possible by increasing dimension S.

The angular and axial restoring forces in the table below left are given at maximum deflections. The chart can be used to determine forces across the full deflection range. The nonlinear characteristics can detune a system to prevent high amplitude axial vibration.

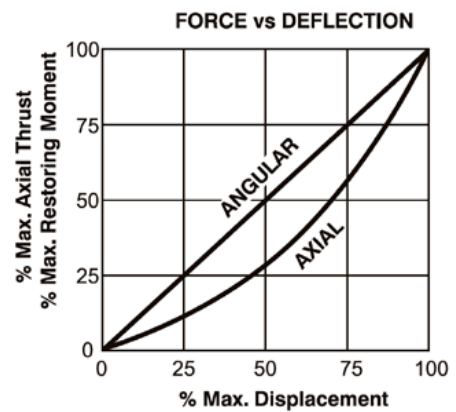

Balance Recommendations

The inherent balance of the RSK range meets AGMA standard 9000-C90 class 9. The adjacent chart relates the RSK sizes to operating speeds on the basis of this AGMA class 9 characteristic to provide a general guide to determine if dynamic balance improvement is necessary.

When balancing improvement is requested. Will dynamically balance the transmission unit. Hubs may also be dynamically balanced, and this will usually be carried out after machining the bore but before cutting single keyways.

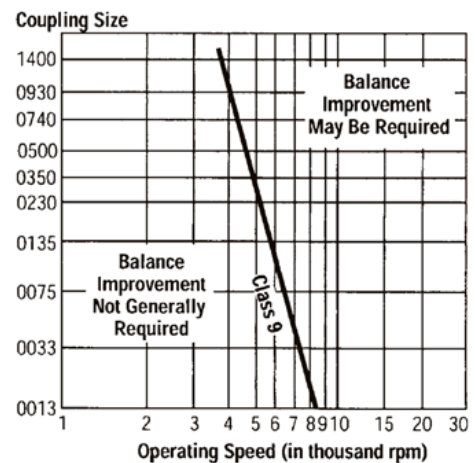

- All dimensions are in mm unless otherwise specified.
- In view of our constant endeavour to improve quality of our products, we reserve the right to alter or change specifications without prior notice.